

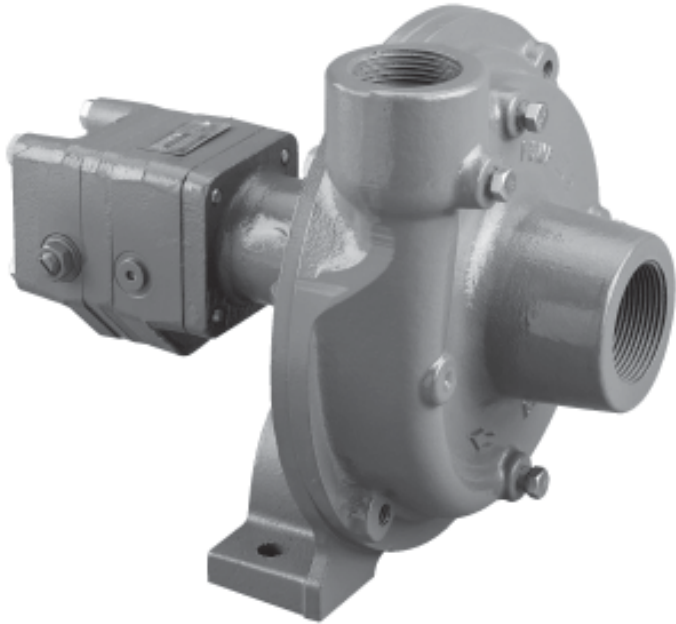

High Performance Hydraulic Motor Driven Centrifugal Pump



FMC-150-HYD-206

- Suction 1-1/2" Discharge 1-1/4"
- Recommended for use on the following Hydraulic Systems:
 - ✓ Pressure Compensating Closed Center
 - ✓ Load Sensing or Pressure Flow Compensating Closed Center
 - ✓ Open Center from 7 to 16 GPM
- Integral Needle Valve bypasses up to 9 GPM on Open Center Systems
- Standard Viton® Carbon/Ceramic seal or Optional Severe Duty Silicon Carbide Mechanical Seal
- Chemical Resistant Valox® or Optional Cast Iron Impeller
- Stainless Steel Shaft and Wear Ring

Valox® is a registered trademark of GE Plastics.
 Viton® is a registered trademark of DuPont Dow Elastomers.

PERFORMANCE CHART

SHUT-OFF 0 GPM	40 GPM	60 GPM	80 GPM	100 GPM	120 GPM
120 PSI	116 PSI	112 PSI	110 PSI	88 PSI	53 PSI
100 PSI	97 PSI	92 PSI	84 PSI	74 PSI	46 PSI
80 PSI	75 PSI	70 PSI	61 PSI	52 PSI	20 PSI
60 PSI	57 PSI	57 PSI	43 PSI	29 PSI	-

Use the SHUT-OFF pressure of your spraying system to determine which line of data applies. The hydraulic system input pressure and flow will vary within the chart. Contact factory for more data.

MAXIMUM SHUT-OFF PRESSURE - 120 PSI

DIMENSIONS

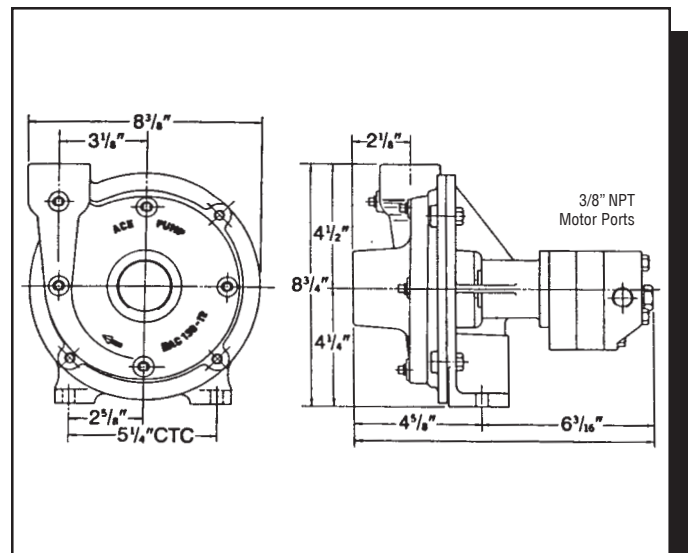



FMC-150-HYD-206

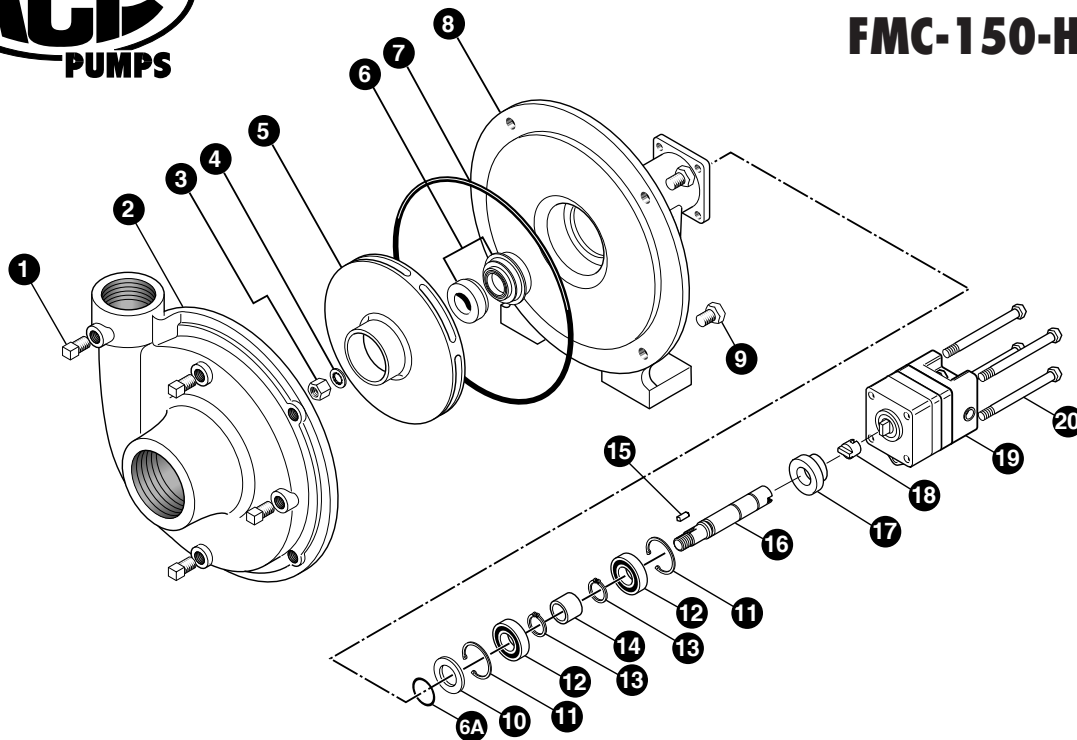

REF. #	PART NUMBER	EDP #	DESCRIPTION	REQ.
1	BAC-53	41110	Pipe plug	4
1	41120	41120	Pipe plug, stainless steel (optional)	4
2	BAC-12-150	40255	Volute, 1-1/2" x 1-1/4"	1
3	BAC-23-A	40391	Nut, 3/8" NF, cad plated	1
4	BAC-24-HYD-SS	40400	Washer, 3/8" star, stainless steel	1
5	BAC-26-150-P	40446	Impeller, Valox, keyway	1
5	BAC-26-150-CI	40445	Impeller, cast iron, keyway (optional)	1
*6	BAC-7V	40151	Seal, mechanical, Viton (includes 40160 O-Ring)	1
6	BAC-7SC	40152	Seal, mechanical, silicon carbide (includes 40160 O-Ring) (optional)	1
6A	40160	40160	O-ring, shaft seal	1
*7	BAC-4-150	40015	O-ring, body seal	1
8	BAC-14-150-HYD	40305	Mounting frame (for 200 Series hydraulic motor)	1
9	40950	40950	Cap screw, 3/8" NC x 3/4" hex head	4
9	40930	40930	Cap screw, 3/8" NC x 3/8" hex head, stainless steel (optional)	4
10	BAC-54	41130	Slinger	1
11	BAC-33	40810	Snap ring, internal, BAC-14 mounting frame	2
12	BAC-37	40870	Ball Bearing, sealed, BAC-6 shaft	2
13	BAC-32	40790	Snap ring, external, BAC-6 shaft	2
14	BAC-32-S	40795	Spacer for BAC-6 shaft	1
15	BACH-25	40420	Key, 1/8" x 1/8" x 1/2"	1
16	BAC-6-HYD-SS	40061	Shaft, 5/8" diameter, keyway and tang slot, stainless steel	1
17	S200	40161	Seal support spacer for 200 Series HYD motor, effective 6/00	1
18	BAC-76-HYD	41380	Coupling for hydraulic motor	1
19	BAC-75-HYD-206	41372	Hydraulic motor, 7 GPM	1
20	41258	41258	Cap screw, 5/16" N. C. x 3-3/4" Hex head (for 206 motor)	4
#	RK-FMC-150	52710	Repair kit for FMC-150 series pump	-
#	RK-BAC-75-HYD	41371	Repair kit for 200 Series motor	-
#	RK-BAC-75-HYD-L	41374	Repair kit for 200-L Series motor	-

* Items included in pump repair kit.

Ace Pump Corporation • P.O. Box 13187 - 1650 Channel Avenue • Memphis, TN 38113
www.AcePumps.com • Phone: 901-948-8514 • Fax: 901-774-6147

Ace Form # FMC-150-HYD
 Revised 04/04

General Advantages of a Hydraulic Motor Driven Centrifugal Pump

Ace developed the first hydraulic motor driven pump at the request of John Deere in 1969. Many of the original pumps are still operating today after more than 30 years of service.

Centrifugal pump design provides good resistance to abrasive solutions and extra flow for agitation. The advantages of the hydraulic motor driven pump are mounting versatility, customized performance, and ease of maintenance. All hydraulic driven pumps are equipped with a stainless steel shaft and wear ring for excellent corrosion resistance.

Mounting Versatility :

The location of the pump is not tied to the PTO or engine drive shaft; the pump can be mounted in a variety of locations to suit application requirements.

Customized Performance :

The performance is dependent on the supply of hydraulic oil to the motor and not necessarily tied to engine speed. A hydraulic driven pump can produce higher pressures than PTO or belt driven pumps. They can also hold constant pressure at varying engine speeds on closed center hydraulic systems.

Easy Maintenance :

On a hydraulic driven pump there are no belts to align or break. Separate pump and hydraulic motor shafts simplify repair and replacement. Two main pump bearings support shaft loads. All pumps are equipped with easily replaceable Viton[®] mechanical seals.

The Ace gear type hydraulic motor is more efficient than gerotor type motors, and is less subject to damage by contamination than the gerotor design. A built-in needle valve allows for the bypass of up to 9 GPM excess hydraulic fluid on open center systems. The standard motor has a reverse flow check valve which prevents backward hookup and a coasting check which protects the motor seal from the flywheel effect of the impeller. A restrictor orifice is included with pump models recommended for pressure compensating closed center systems.